

Features

- Wide input voltage: 8V-48V
- Up to 0.6A Output Current
- Switching Frequency 900kHz
- Low Typical 1 μ A Shutdown Current
- Stable with Low ESR Ceramic Output
- SKIP mode provides extremely high light load efficiency
- 0.8V Voltage Reference
- Integrated 450m Ω High-Side MOSEFT
- Cycle-by-cycle Current Limit Protection
- Peak Current Mode with Internal Compensation
- Thermal Shutdown
- Compact package: SOT23-6

Applications

- IP CAM
- LCD TV
- Smart Home Applications
- Telecom and Datacom Systems
- Power over Ethernet Applications
- Universal voltage stabilizer and buck converter

General Description

This has a wide input voltage range of 8V-48V, minimizing the need for external surge suppression components, making it an ideal choice for industrial applications with a wide input range and multi cell battery pack applications.

It features an integrated power MOSFET and adopts a peak current detection mode architecture with internal compensation, providing a rated maximum output current capability of 0.6A and excellent load and input transient response.

Pin out (top view)

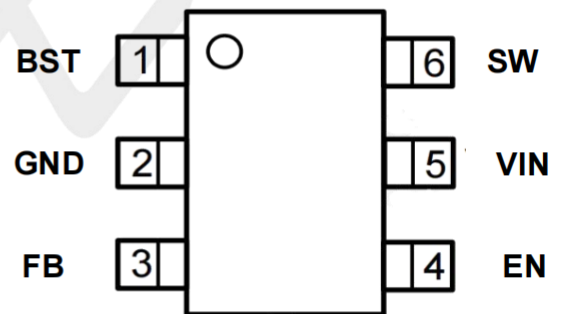

Pin Configurations

Pin	Name	Function
1	BST	Bootstrap capacitor connection for high-side MOSFET driver. Connect a high quality 100nF capacitor from BS to SW.
2	GND	Ground
3	FB	Feedback input pin, connect to the feedback divider to set VOUT.VFB:0.8V.
4	EN	Output enable pin. Enable high output; Set low and turn off output
5	VIN	Connect to power supply and bypass capacitors CIN. Path from VIN pin to high frequency bypass CIN and GND must be as short as possible.
6	SW	Switching output of the regulator. Internally connected to high-side power MOSFET. Connect to power inductor.

Absolute Maximum Ratings (Note1)

Parameter	Min	Max	Unit
Input Supply Voltage, SW	-0.3	55	V
BS to SW Voltage	-0.3	6	V
FB Voltage	-0.3	6	V
EN Voltage	-0.3	7	V
Storage Temperature Range	-65	150	°C
Junction Temperature <small>(Note2)</small>	-40	125	°C
Power Dissipation	--	0.5	W
Lead Temperature (Soldering, 10s)	--	260	°C

Note 1: Absolute Maximum Ratings are those values beyond which the life of a device may be impaired.

Note 2: T_J is calculated from the ambient temperature T_A and power dissipation P_D according to the following formula: $T_J = T_A + (P_D) \times \theta_{JA}$.

ESD Rating (Note4)

Items	Description	Value	Unit
V_{ESD_HBM}	Human Body Model for all pins JEDEC JS-001	±2000	V
V_{ESD_CDM}	Charged Device Model for all pins JESD22-C101	±1000	V

Recommended Operating Conditions

Items	Description	Min	Max	Unit
V_{IN}	Voltage Range	8	48	V
V_{EN}	EN Voltage	2	5	V
T_J	Operating Junction Temperature	-40	125	°C
T_A	Operating Ambient Temperature	-40	85	°C

Thermal Resistance (Note3)

Items	Description	Value	Unit
θ_{JA}	Junction-to-ambient thermal resistance	100	°C/W
θ_{JC}	Junction-to-case(top) thermal resistance	58	°C/W

Note 3: The data tested by surface mounted on a 1 inch² FR-4 board with 2OZ copper.

Note 4: Guaranteed by design.

Electrical Characteristics

($V_{IN}=24V$, $V_{OUT}=12V$, $T_A = 25^{\circ}C$, unless otherwise noted.)

Parameter	Symbol	Conditions	Min	Typ	Max	Unit
Input Voltage Range	V_{IN}		8	--	48	V
Input Quiescent Current	I_Q	No witch	--	200	--	μA
Shutdown Current	I_{SD}	$V_{EN}= 0V$	--	--	1	μA
Feedback Threshold Voltage	V_{FB}	$T_J = 25^{\circ}C$	0.775	0.8	0.825	V
FB Pin input current	I_{FB}		--	100	120	nA
EN Rising Threshold from Standby Mode	V_{EN_R}		--	1.5	1.8	V
EN Shutdown Threshold	V_{EN_SD}		0.6	1	--	V
EN Pull-up Current Source	I_{EN}	$V_{EN}= 6V$	--	100	--	μA
Soft start Time	t_{SS}		--	0.6	--	ms
Internal Cycle-by-cycle Current limit	I_{LIM}		1	1.2	1.4	A
SW leakage	I_{LX_LEAK}		--	0.8	--	μA
Zero crossing detection	I_{ZC}	DCM mode, light load	--	90	--	mA
Switch On-Resistance (high side)	R_{DSO_HS}		--	450	--	m Ω
Switch On-Resistance (Low side)	R_{DSO_LS}		--	470	--	m Ω
Switching Frequency	f_{SW}		--	900	--	kHz
Minimum Turn-on Time <small>(Note 4)</small>	t_{ON_MIN}		--	100	--	ns
Thermal Shutdown Threshold <small>(Note 4)</small>	T_{SDN}		--	150	--	$^{\circ}C$
Thermal Shutdown Hysteresis <small>(Note 4)</small>	T_{SDN_HY}		--	25	--	$^{\circ}C$
Maximum switch duty cycle ratio	D_{MAX}		--	93	--	%

Note 4: Guaranteed by design.

BLOCK DIAGRAM

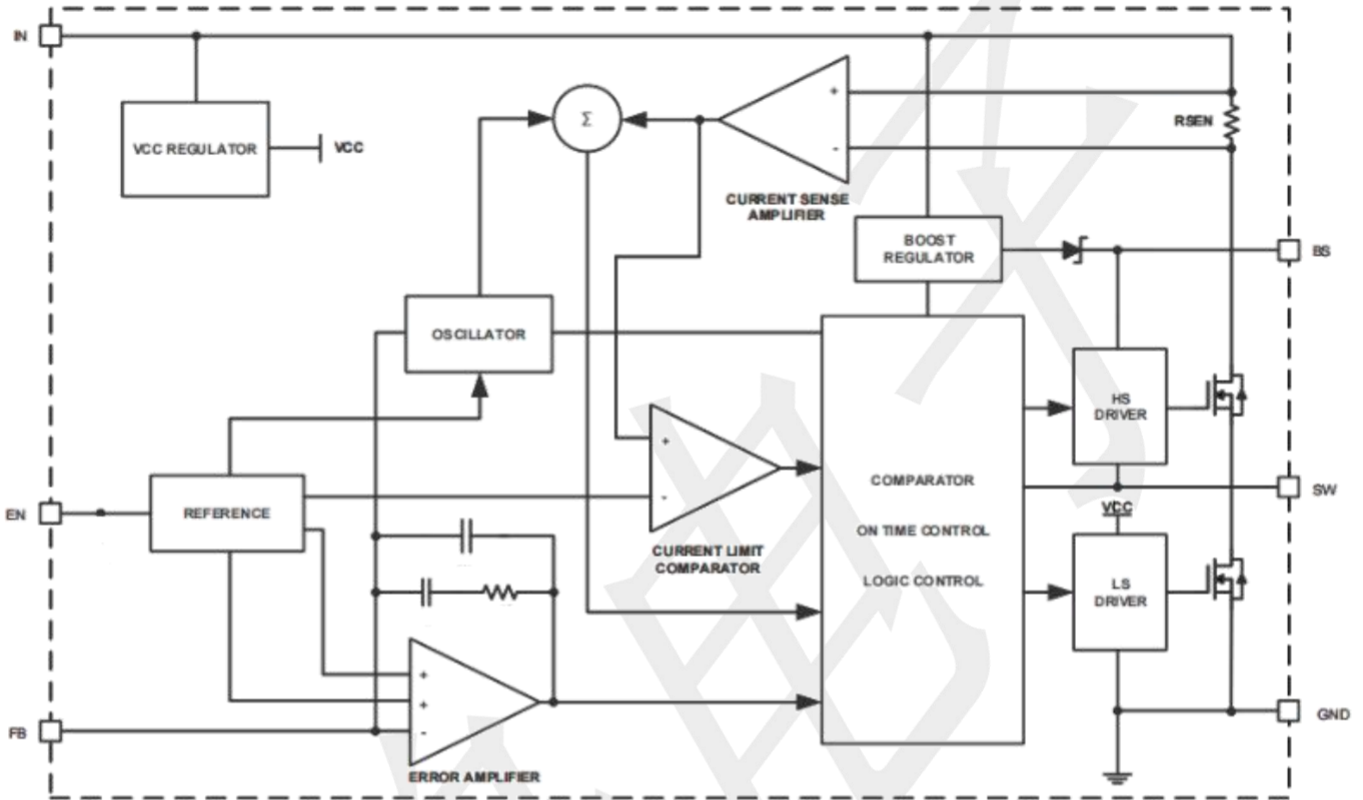

Typical Application Circuits

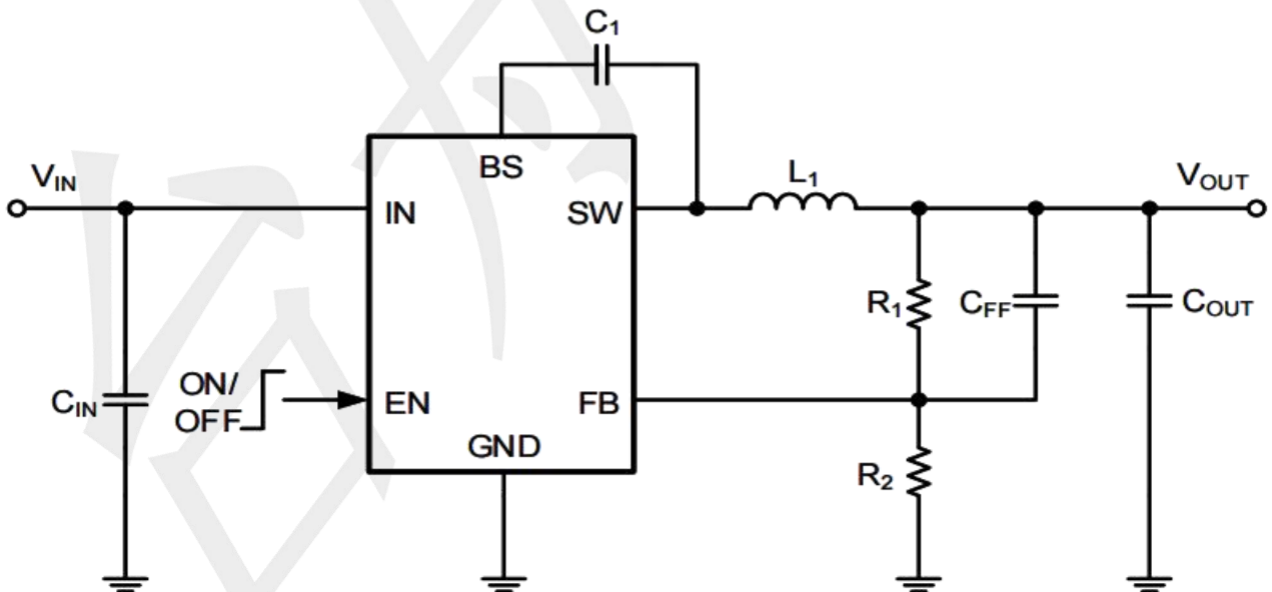

Function Description

Because of the high integration in the IC, the application circuit based on this regulator IC is rather simple. Only input capacitor CIN, output capacitor COUT, output inductor L and feedback resistors (R1 and R2) need to be selected for the targeted applications specifications.

Feedback resistor dividers R1 and R2

Choose R1 and R2 to program the proper output voltage. To minimize the power consumption under light loads, it is desirable to choose large resistance values for both R1 and R2. A value of between 10kΩ and 1MΩ is highly recommended for both resistors.

Input capacitor CIN

The ripple current through input capacitor is calculated as:

To minimize the potential noise problem, place a typical X5R or better grade ceramic capacitor really close to the IN and GND pins. Care should be taken to minimize the loop area formed by CIN, and IN/GND pins. In this case, a 4.7uF low ESR ceramic capacitor is recommended.

Output capacitor COUT

The output capacitor is selected to handle the output ripple noise requirements. Both steady state ripple and transient requirements must be taken into consideration when selecting this capacitor. For the best performance, it is recommended to use X5R or better grade ceramic capacitor greater than 22uF capacitance.

Output inductor L

There are several considerations in choosing this inductor.

1) Choose the inductance to provide the desired ripple current. It is suggested to choose the ripple current to be about 40% of the maximum output current. The inductance is calculated as:

$$L = \frac{V_{OUT} (1 - V_{OUT}/V_{IN,MAX})}{F_{SW} \times I_{OUT,MAX} \times 40\%}$$

where Fsw is the switching frequency and IOUT,MAX is the maximum load current. The regulator IC is quite tolerant of different ripple current amplitude. Consequently, the final choice of inductance can be slightly off the calculation value without significantly impacting the performance.

2) The saturation current rating of the inductor must be selected to be greater than the peak inductor current under full load conditions.

$$I_{SAT, MIN} > I_{OUT, MAX} + \frac{V_{OUT}(1-V_{OUT}/V_{IN,MAX})}{2 \cdot F_{SW} \cdot L}$$

3) The DCR of the inductor and the core loss at the switching frequency must be low enough to achieve the desired efficiency requirement. It is desirable to choose an inductor with $DCR < 50m\Omega$ to achieve a good overall efficiency.

External Bootstrap Cap

This capacitor provides the gate driver voltage for internal high side MOSEFET. A 100nF low ESR ceramic capacitor connected between BS pin and SW pin is recommended.

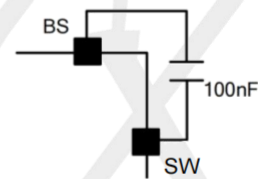

Load Transient Considerations

The regulator IC integrates the compensation components to achieve good stability and fast transient responses. In some applications, adding a 22pF ceramic cap in parallel with R1 may further speed up the load transient responses and is thus recommended for applications with large load transient step requirements.

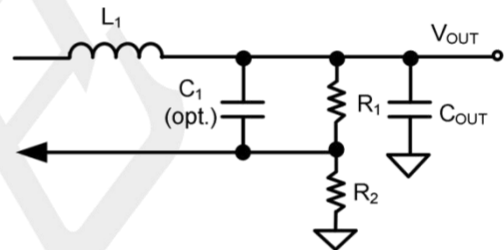

Layout Design

The layout design of regulator is relatively simple. For the best efficiency and minimum noise problem, we should place the following components close to the IC: C_{IN} , L, R1 and R2.

- 1) It is desirable to maximize the PCB copper area connecting to GND pin to achieve the best thermal and noise performance. If the board space allowed, a ground plane is highly desirable.
- 2) C_{IN} must be close to Pins IN and GND. The loop area formed by C_{IN} and GND must be minimized.
- 3) The PCB copper area associated with SW pin must be minimized to avoid the potential noise problem.
- 4) The components R1 and R2, and the trace connecting to the FB pin must NOT be adjacent to the SW net on the PCB layout to avoid the noise problem.
- 5) If the system chip interfacing with the EN pin has a high impedance state at shutdown mode and the IN pin is connected directly to a power source such as a Li-Ion battery, it is desirable to add a pull down 1Mohm resistor between the EN and GND pins to prevent the noise from falsely turning on the regulator at shutdown mode.

Package Outline Dimensions (unit: mm)

SOT23-6

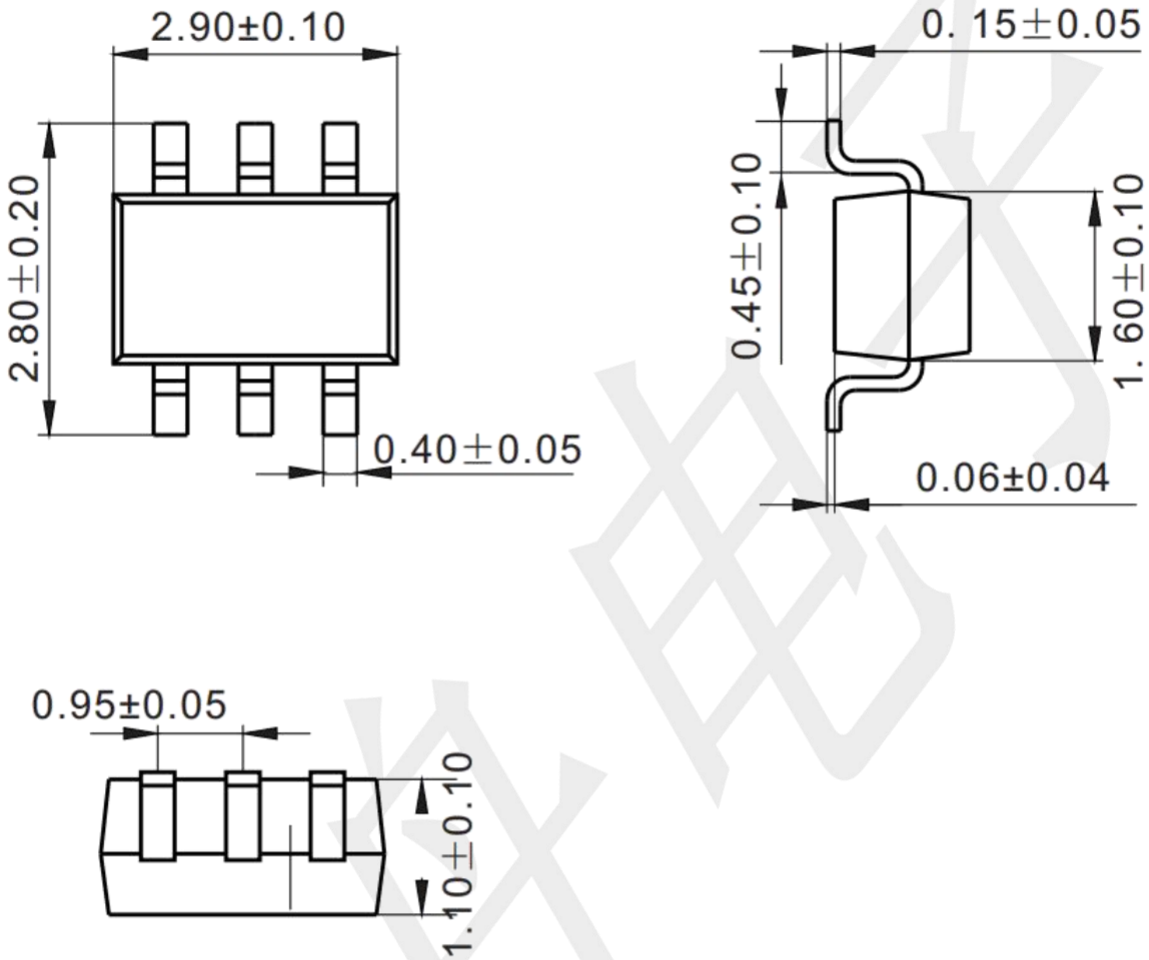

Mounting Pad Layout (unit: mm)

