

Features

- Output Adjustable from 1.222V to 22V
- Maximum Duty Cycle 100%
- 2A Constant Output Current Capability
- EN pin with hysteresis function
- Built in thermal shutdown function
- Built in current limit function
- TTL shutdown capability
- package: SOP8

Applications

- Battery Chargers
- NICs / Switches / Hubs
- LCD TV
- DSL Modem
- Access Point Router
- Negative Voltage Power Supplies
- Set Top Box

General Description

The is a 380KHz fixed frequency PWM buck (step-down) DC/DC converter, capable of driving a 2A load with high efficiency, low ripple and excellent line and load regulation. Requiring a minimum number of external components, the regulator is simple to use and include internal frequency compensation and a fixed-frequency oscillator.

Pinout (top view)

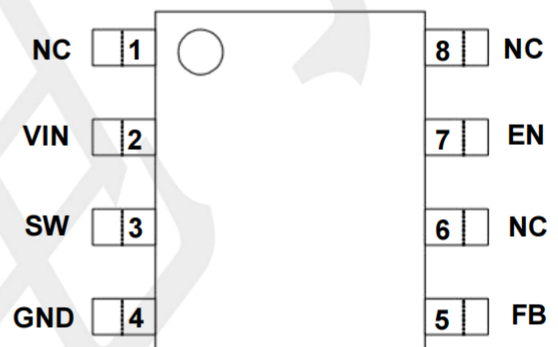

SOP8

Pin Configurations

| Pin Number | Pin Name | Pin Function |
|------------|----------|---|
| 1 | NC | No Connected. |
| 2 | VIN | Power Supply Input. |
| 3 | SW | Power Switch Output Pin (SW). Output is the switch node that |
| 4 | GND | ground pin. |
| 5 | FB | Feedback Pin (FB). Through an external resistor divider network. |
| 6 | NC | No Connected. |
| 7 | EN | Enable Pin. Drive EN pin low to turn off the device, drive it high to turn it on. Floating is default high. |
| 8 | NC | No Connected. |

Absolute Maximum Ratings

| Parameter | Symbol | Value | Unit |
|--|--------|--------------------|------|
| Input Voltage | Vin | -0.3 to 26 | V |
| Feedback Pin Voltage | VFB | -0.3 to Vin | V |
| EN Pin Voltage | VEN | -0.3 to Vin | V |
| Output Switch Pin Voltage | VSW | -0.3 to Vin | V |
| Power Dissipation | PD | Internally limited | mW |
| (Junction to Ambient, No Heatsink, Free Air) | RJA | 100 | °C/W |
| Operating Junction Temperature | TJ | -10 to 85 | °C |
| Storage Temperature | TSTG | -65 to 150 | °C |
| Lead Temperature (Soldering, 10 sec) | TLEAD | 260 | °C |
| ESD (HBM) | | 2000 | V |

Note1: Stresses greater than those listed under Maximum Ratings may cause permanent damage to the device. This is a stress rating only and functional operation of the device at these or any other conditions above those indicated in the operation is not implied. Exposure to absolute maximum rating conditions for extended periods may affect reliability.

BLOCK DIAGRAM

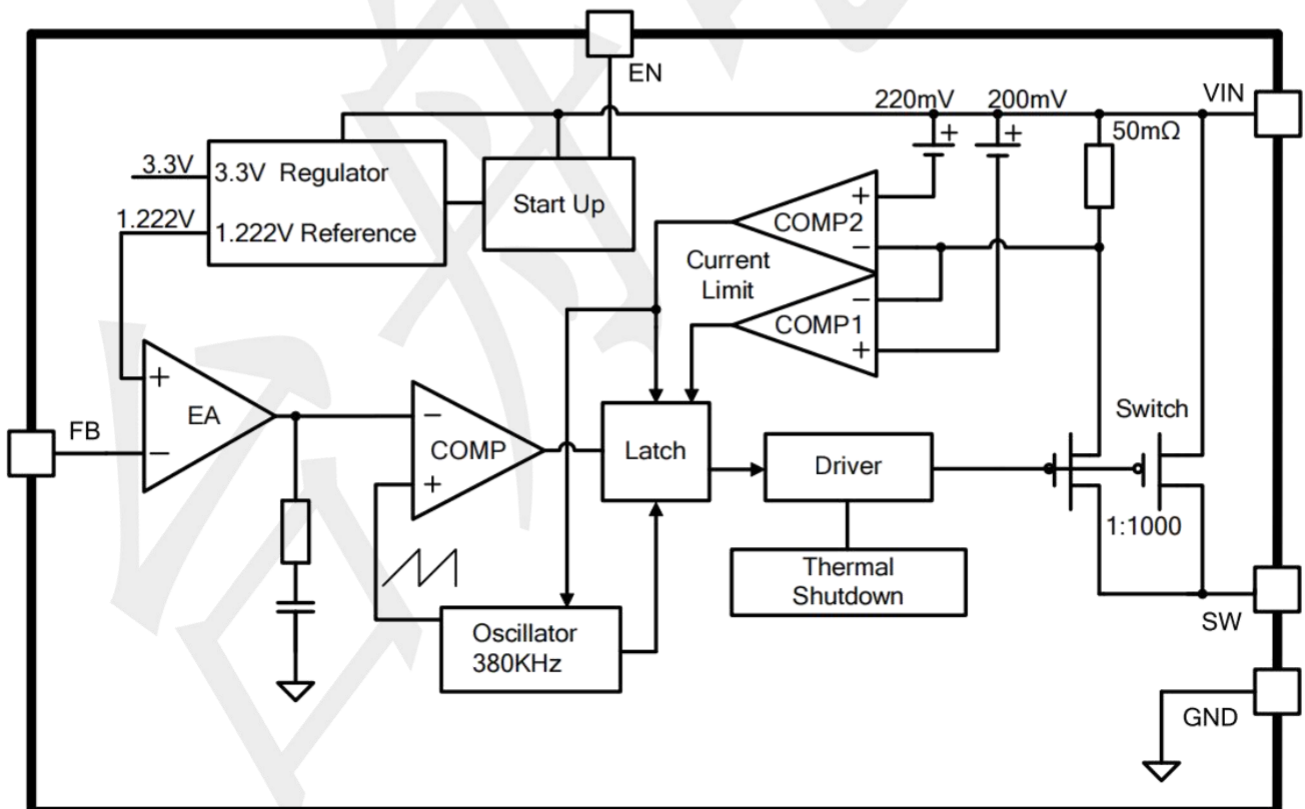

Electrical Characteristics

($V_{in} = 12V$, $GND=0V$, V_{in} & GND parallel connect a 220uf/50V capacitor; $I_{out}=500mA$, $T_a = 25^{\circ}C$; the others floating unless otherwise specified.)

| Parameters | Symbol | Test Condition | Min. | Typ. | Max. | Unit |
|------------------------------|-----------|--|-------|-------|-------|---------|
| Input operation voltage | V_{in} | | 3.6 | -- | 25 | V |
| Shutdown Supply Current | I_S | $V_{EN}=0V$ | -- | 60 | 200 | μA |
| Quiescent Supply Current | I_q | $V_{EN} = 2V$, $V_{FB} = V_{in}$ | -- | 3 | 5 | mA |
| Oscillator Frequency | F_{osc} | | 323 | 380 | 437 | Khz |
| Switch Current Limit | I_L | $V_{FB} = 0V$ | -- | 4 | -- | A |
| EN Pin Threshold | V_{EN} | High (Regulator ON) | -- | 1.3 | -- | V |
| | | Low (Regulator OFF) | -- | 0.6 | -- | V |
| EN Pin Input Leakage Current | I_H | $V_{EN} = 2V$ (ON) | -- | 1 | 15 | μA |
| | I_L | $V_{EN} = 0V$ (OFF) | -- | 1 | 15 | μA |
| Max. Duty Cycle | D_{MAX} | $V_{FB}=0V$ | -- | 100 | -- | % |
| Feedback Voltage | V_{FB} | $V_{in} = 7V$ to 28V, $V_{out}=5V$, $I_{load}=0.2A$ to 2A | 1.186 | 1.222 | 1.258 | V |
| Efficiency | η | $V_{in}=12V$, $V_{out}=5V$, $I_{out}=2A$ | -- | 83 | -- | % |

Note: Output switch tests are performed under pulsed conditions to minimize power dissipation.

Typical Application Circuit

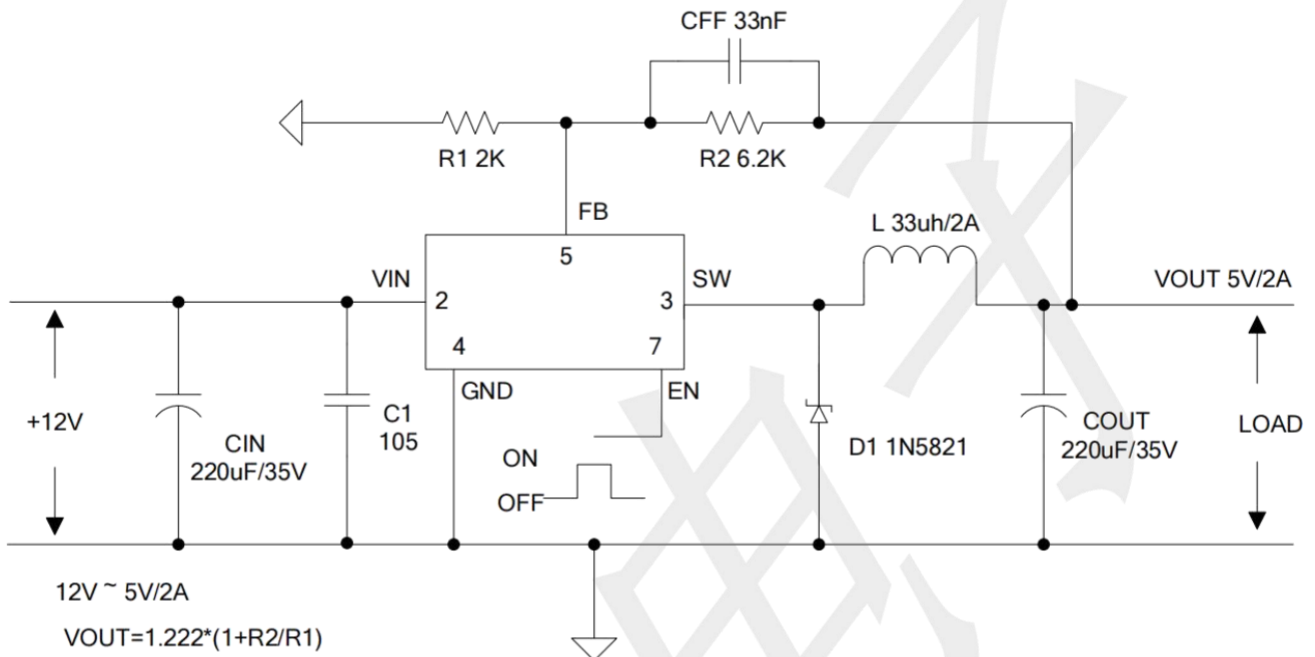

System Parameters Test Circuit (12V ~ 5V/2A)

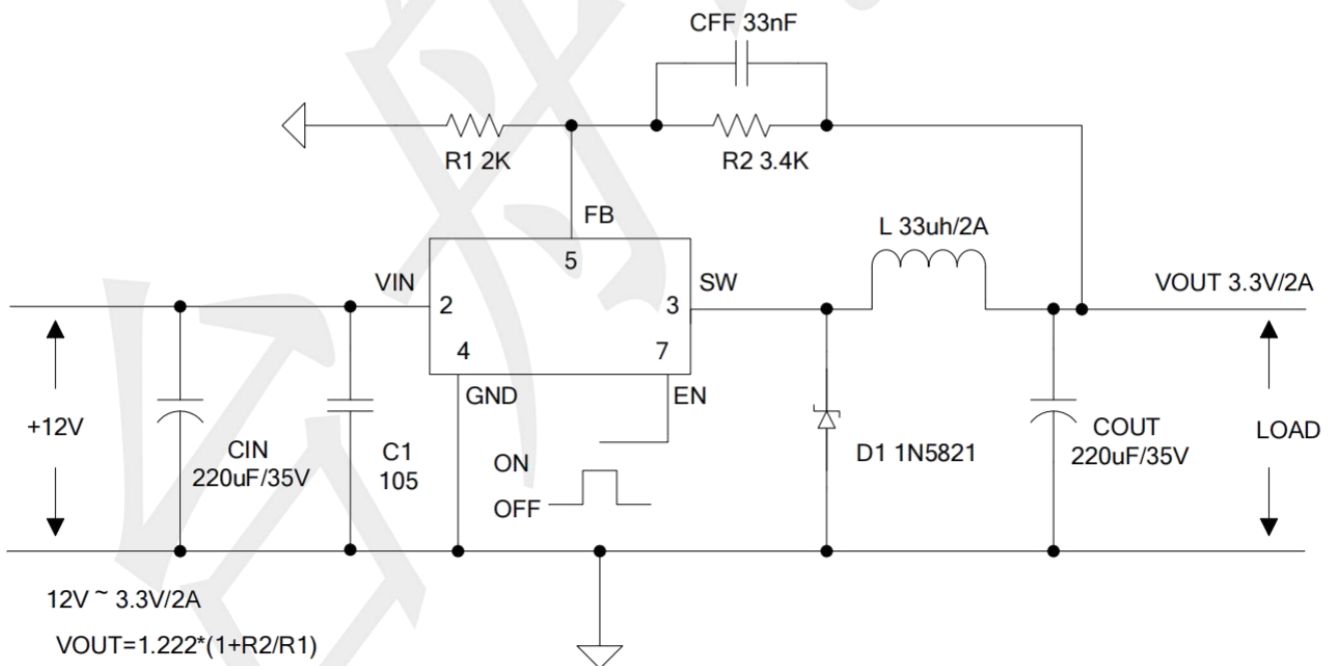

System Parameters Test Circuit (12V ~ 3.3V/2A)

Test Circuit and Layout guidelines

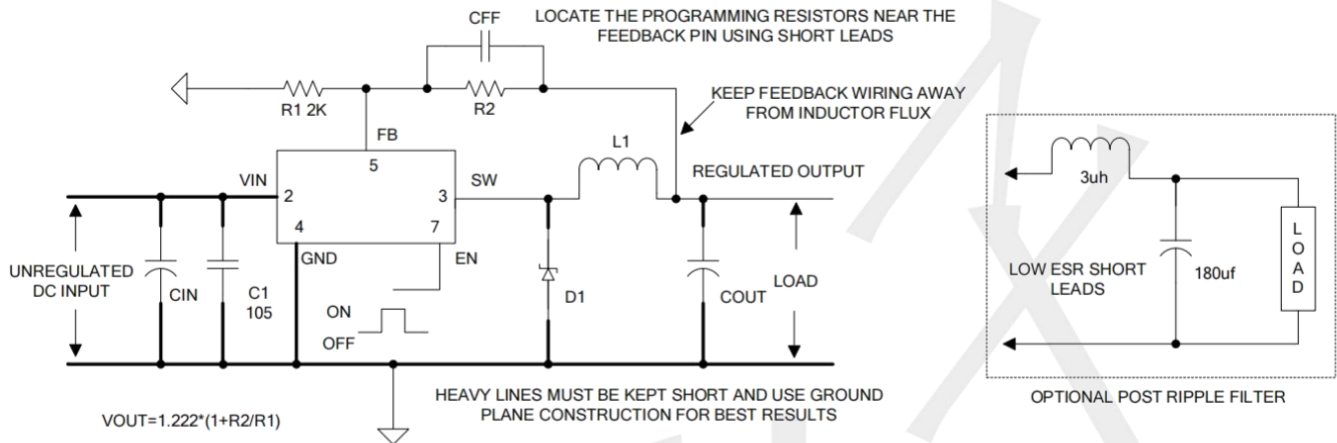

Standard Test Circuits and Layout Guides

Select R1 to be approximately 2K, use a 1% resistor for best stability.

C1 and CFF are optional; in order to increase stability and reduce the input power line noise, C1 must be placed near to VIN and GND;

For output voltages greater than approximately 10V, an additional capacitor CFF is required. The compensation capacitor is typically between 100 pf and 33 nf, and is wired in parallel with the output voltage setting resistor, R2. It provides additional stability for high output voltage, low input-output voltages, and/or very low ESR output capacitors, such as solid tantalum capacitors.

$CFF = 1 / (31 * 1000 * R2)$; This capacitor type can be ceramic, plastic, silver mica, etc. (Because of the unstable characteristics of ceramic capacitors made with Z5U material, they are not recommended.)

Schottky Diode Selection Table

| Current | Surface Mount | Through Hole | VR (The same as system maximum input voltage) | | | | |
|---------|---------------|--------------|---|--------|--------|--------|--------|
| | | | 20V | 30V | 40V | 50V | 60V |
| 1A | | √ | 1N5817 | 1N5818 | 1N5819 | -- | -- |
| | | √ | 1N5820 | 1N5821 | 1N5822 | -- | -- |
| | | √ | MBR320 | MBR330 | MBR340 | MBR350 | MBR360 |
| 3A | √ | | SK32 | SK33 | SK34 | SK35 | SK36 |
| | √ | | -- | 30WQ03 | 30WQ04 | 30WQ05 | -- |
| | | √ | -- | 31DQ03 | 31DQ04 | 31DQ05 | -- |
| | | √ | SR302 | SR303 | SR304 | SR305 | SR306 |

Package Outline Dimensions (unit: mm)

SOP8

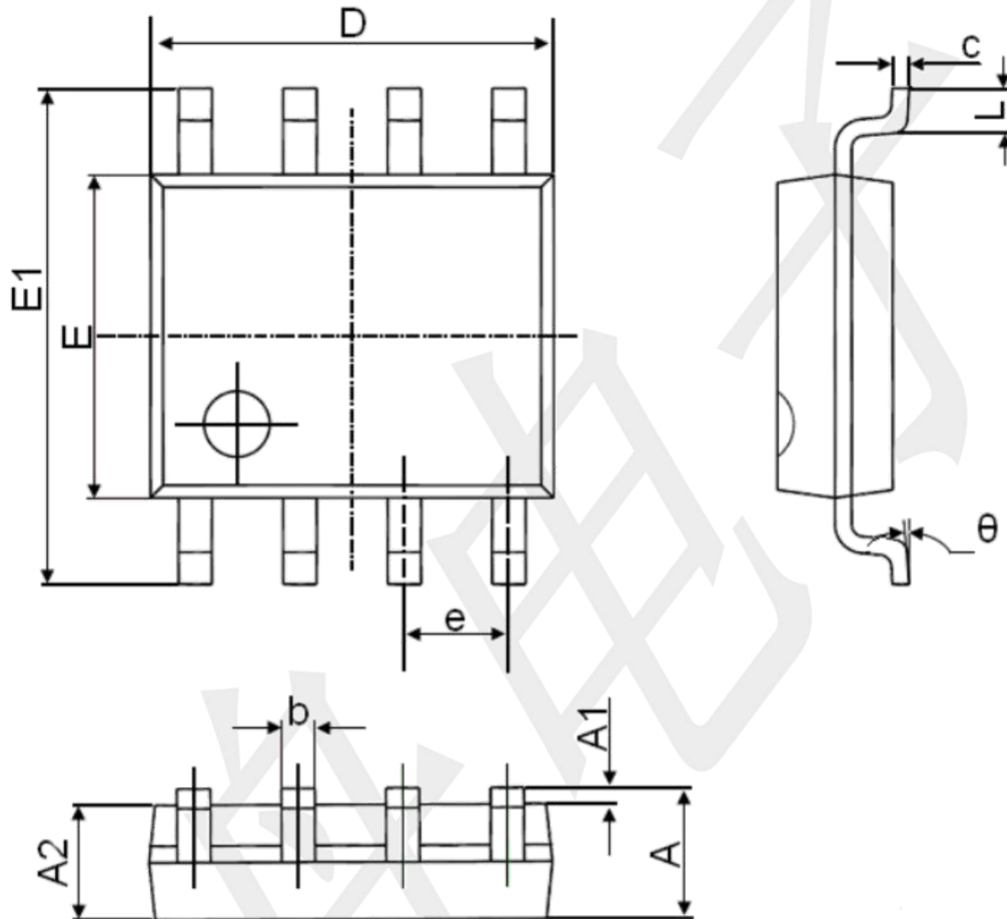

| Symbol | Dimensions In Millimeters | | Dimensions In Inches | |
|----------|---------------------------|-------|----------------------|-------|
| | Min. | Max. | Min. | Max. |
| A | 1.350 | 1.750 | 0.053 | 0.069 |
| A1 | 0.100 | 0.250 | 0.004 | 0.010 |
| A2 | 1.350 | 1.550 | 0.053 | 0.061 |
| b | 0.330 | 0.510 | 0.013 | 0.020 |
| c | 0.170 | 0.250 | 0.006 | 0.010 |
| D | 4.700 | 5.100 | 0.185 | 0.200 |
| E | 3.800 | 4.000 | 0.150 | 0.157 |
| E1 | 5.800 | 6.200 | 0.228 | 0.244 |
| e | 1.270(BSC) | | 0.050(BSC) | |
| L | 0.400 | 1.270 | 0.016 | 0.050 |
| θ | 0° | 8° | 0° | 8° |